

PRODUCT DRAWINGS (产品图纸)

RoHS
Compliant

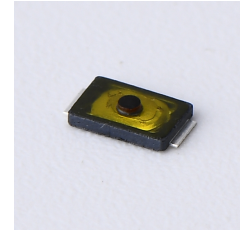

主要技术参数、性能 The Main Thchnology Performance

额定电流、电压 Rate voltage,current	50mA DC12V
接触电阻 Contact resistance	≤100mΩ
按力 Operating force	±50gf
行程 Travel	0.15±0.10mm
绝缘电阻 Insulated resistance	≥100MΩ
介电强度 Dielectric strength	≥100VAC/1min

E	胶点	PPA	1	黑色
D	防尘膜	聚酰亚胺	1	黄膜/银膜
C	弹片	不锈钢	2	镀银
B	本体	PPA	1	黑色
A	卡件	磷铜	1	镀银
项目 ITEM	名称 DESCRIPTION	材质 MATERIAL	数量 QTY	表面处理/颜色 FINISH/COLOR

高度Hmm				
0.65				

按力gf		
180	260	其它
寿命/万次		
≥3	≥5	≥10

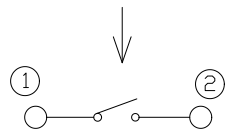
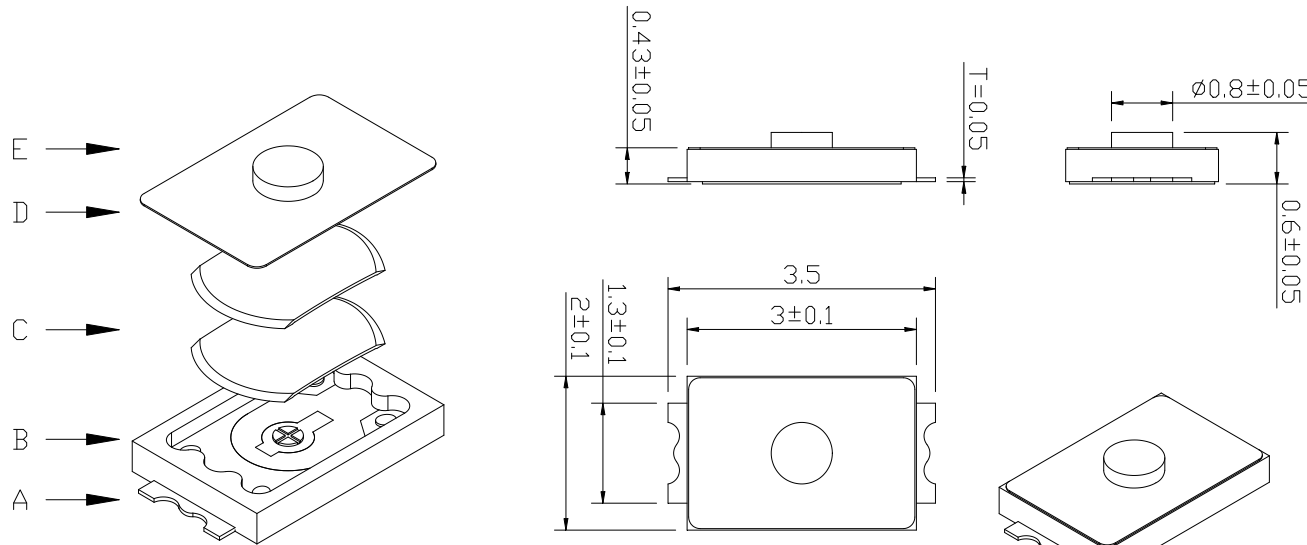

电路图
CIRCUIT DIAGRAM

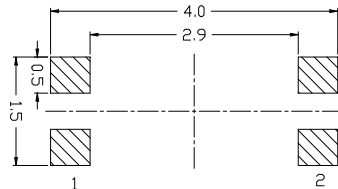

PCB.焊接图
PCB.WELDING DRAWING

					第一视角 FIRST VIEW		名称/NAME: 轻触开关 TACTILE SWITCH	
					比例 SCALE		型号/MODEL: 2X3带外黑胶点薄膜U型平二脚立贴	
标记 SING	处数 FREQUENCY	更改文件号 REVISION	签名 APPROVED	日期 DATE	比例 SCALE	一般公差 GENERAL TOLERANCE		
设计 DESIGN	叶博靖		2025.02.15		单位 UNIT	mm	≥0~2<	±0.15
审核 CHECKED	叶纪镇		2025.02.16		重量 WEIGHT		≥2~5<	±0.25
批准 APPROVED	叶纪杰		2025.02.17				≥5	±0.35
							角度 ANGLE	±0.5°



深圳市兴联合电子有限公司
Shenzhen Kinglian Electronics Co., Ltd